

200-V/160 Ohm, 1 Form A, Small-Signal Solid State Relay

Technical Data

HSSR-8200

Features

- Compact Solid-State Bidirectional Signal Switch
- Normally-Off Single-Pole Relay Function (1 Form A)
- Very High Output Off-Impedance: 10,000 Gigaohms Typical at 25°C
- Very Low Output Offset Voltage: < 0.5 μV at $I_F = 1 \text{ mA}$
- 200-Volt Output Withstand Voltage at 25°C
- High-Transient Immunity: > 2000 V/ μs
- Monolithic High-Voltage IC
- Operating Range: -40°C to +85°C
- Very Low Input Current (1 mA); CMOS Compatibility
- High-Speed Switching: 50 μs Typical
- 160-Ohm Maximum On-Resistance at 25°C
- Surface Mount Option
- 8-kV ESD Immunity: MIL-STD-883 Method 3015
- Input-to-Output Insulation Voltage: 2500 Vac, 1 Minute
- UL 508 Recognized
- CSA Approved

Applications

- Relay Scanners & Analog Input Modules of Data Acquisition Systems
- Analog Input Modules of Programmable Logic Controllers
- Relay Multiplexers of High-Performance Voltmeters
- Telecommunication Test Instruments
- Functional Tester of Board Test Equipment
- Analog Signal Multiplexer
- Flying Capacitor Multiplexer
- Reed Relay Replacement

Description

The HSSR-8200 consists of a high-voltage integrated circuit optically coupled with a light emitting diode. This device is a solid-state replacement for single-pole, normally-open electromechanical relays used for general purpose switching of analog signals.

The light-emitting diode controls the ON/OFF function of the solid-state relay. The detector contains high voltage MOS transistors and a high speed photosensitive drive circuit. This relay has superior OFF impedance, very low output offset voltage and input drive current.

Functional Diagram

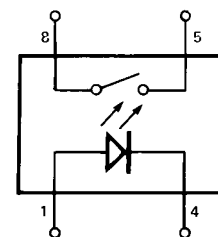
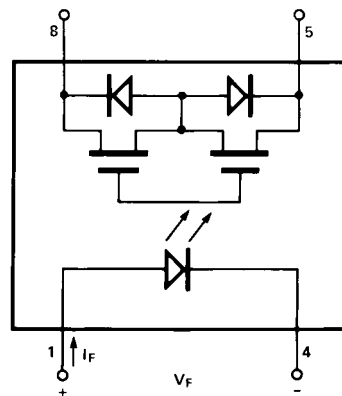

EQUIVALENT RELAY DIAGRAM

TRUTH TABLE (POSITIVE LOGIC)

LED	OUTPUT
ON	L
OFF	H

CAUTION: It is advised that normal static precautions be taken in handling and assembly of this component to prevent damage and/or degradation which may be induced by ESD.

The electrical and switching characteristics of the HSSR-8200 are specified from -40°C to $+85^{\circ}\text{C}$. The low I_F allows compatibility with TTL, LSTTL, and CMOS logic resulting in low power consumption compared to other solid state and mechanical relays.

Selection Guide

6-Pin DIP (300 Mil) Single Channel Package	4-Pin DIP (300 Mil) Dual Channel Package	Maximum Speed t(ON) msec 25°C	Maximum ON Resistance R(ON) Ω 25°C	Maximum Output Voltage VO(off) V 25°C	Maximum Output Current Io(ON) mA 25°C	Minimum Input Current mA	Hermetic 8-Pin Single Channel Packages
HSSR-8400 ^[1]		0.95	10	400	150	5	
HSSR-8060 ^[1]		1.4	0.7	60	750	5	
	HSSR-8200	1.5	200	200	40	1	
		6	1	90	800	5	HSSR-7110 ^[1]

Note:

1. Technical data are on separate HP publication.

Ordering Information

Specify part number followed by Option Number (if desired).

HSSR-8200#XXX

- 300 = Gull Wing Surface Mount Lead Option
- 500 = Tape/Reel Package Option (1 K min)

Option data sheets available. Contact your Hewlett-Packard sales representative or authorized distributor for information.

Schematic

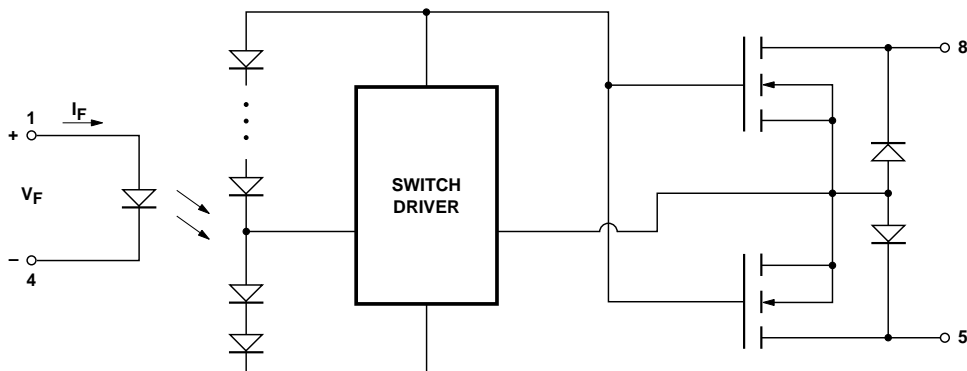

Package Outline Drawings 4-Pin DIP Package (HSSR-8200)

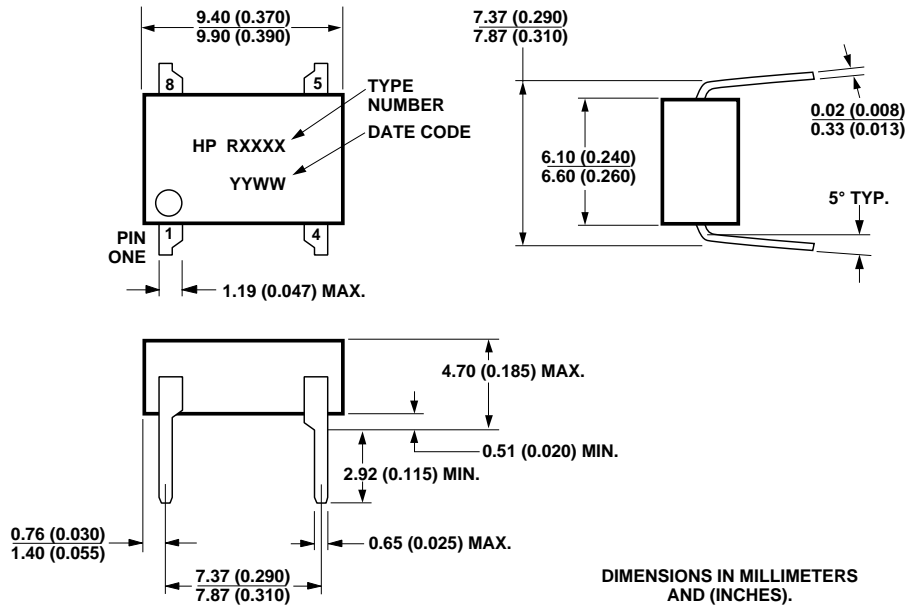

4-Pin DIP Package with Gull Wing Surface Mount Option 300

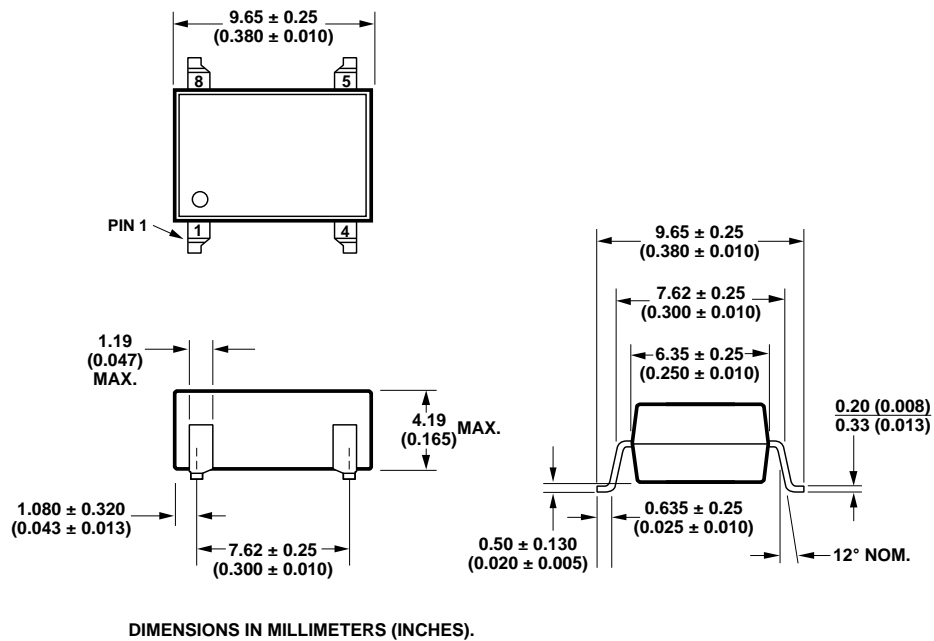

Thermal Profile (Option #300)

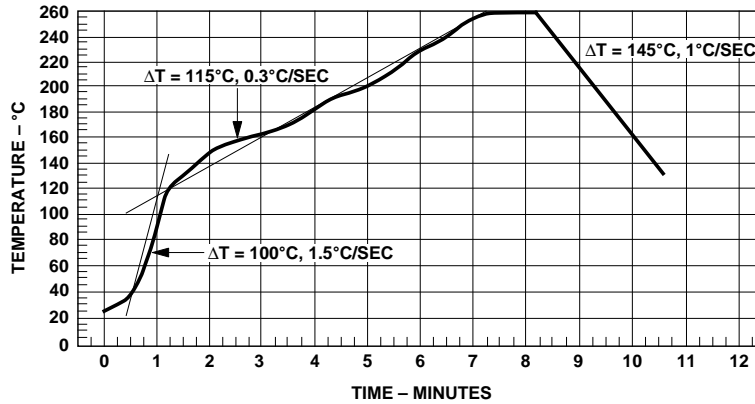

Figure 1. Maximum Solder Reflow Thermal Profile.
(Note: Use of non-chlorine activated fluxes is recommended.)

Regulatory Information

The HSSR-8200 has been approved by the following organizations:

UL

Recognized under UL 508, Component Recognition Program, Industrial Control Switches, File E142465.

CSA

Approved under CAN/CSA-C22.2 No. 14-95, Industrial Control Equipment, File LR 87683.

Insulation and Safety Related Specifications

Parameter	Symbol	Value	Units	Conditions
Min. External Air Gap (External Clearance)	L(IO1)	7.0	mm	Measured from input terminals to output terminals, shortest distance through air
Min. External Tracking Path (External Creepage)	L(IO2)	7.5	mm	Measured from input terminals to output terminals, shortest distance path along body
Min. Internal Plastic Gap (Internal Clearance)		0.5	mm	Through insulation distance, conductor to conductor, usually the direct distance between the photoemitter and photodetector inside the optocoupler cavity
Tracking Resistance (Comparative Tracking Index)	CTI	200	Volts	DIN IEC 112/VDE 0303 PART 1
Isolation Group		IIIa		Material Group (DIN VDE 0110, 1/89, Table 1)

Option 300 – surface mount classification is Class A in accordance with CECC 00802.

Absolute Maximum Ratings

Storage Temperature -55°C to +125°C
 Operating Temperature -40°C to +85°C
 Lead Solder Temperature 260°C for 10 s (1.6 mm below seating plane)
 Average Input Current - I_F 10 mA
 Repetitive Peak Input Current - I_F 20 mA; 50% Duty Cycle
 Transient Peak Input Current - I_F 100 mA
 ($\leq 1 \mu\text{s}$ pulse width; 1 kHz Pulse Repetition Rate)
 Reverse Input Voltage 5 V
 Average Output Current - I_O 40 mA^[1]
 Input Output Insulation Voltage 2500 VAC^[6]
 Output Power Dissipation 320 mW^[2]
 Output Voltage - V_O -200 V to 200 V
 Infrared and Vapor Phase Reflow Temperature
 (Option #300) see Fig. 1, Thermal Profile

Recommended Operating Conditions

Parameter	Symbol	Min.	Max.	Units
Input Current (ON)	$I_{F(ON)}$	1	5	mA
Input Voltage (OFF)	$V_{F(OFF)}$	0	0.6	Volt
Operating Temperature	T_A	-40	+85	°C
Output Voltage	$V_{O(OFF)}$	-200	200	Volt
Output Current	$I_{O(ON)}$	-40	40	mA

DC Electrical Specifications

$-40^{\circ}\text{C} \leq T_A \leq +85^{\circ}\text{C}$, $1 \text{ mA} \leq I_{F(\text{ON})} \leq 5 \text{ mA}$, $0 \text{ V} \leq V_{F(\text{OFF})} \leq 0.6 \text{ V}$, and all Typicals at $T_A = 25^{\circ}\text{C}$ unless otherwise specified.

Parameter	Sym.	Min.	Typ.	Max.	Units	Test Conditions	Fig.	Notes
Output Withstand Voltage	$ V_{O(\text{OFF})} $	200	245		V	$I_O = 1 \mu\text{A}$		
Output On-Resistance	$R_{(\text{ON})}$	70	125	160	Ω	$T_A = 25^{\circ}\text{C}$, $I_O = 1 \text{ MA}$	3, 4, 5	
		40	125	250		$I_O = 1 \text{ MA}$		
		30	100	200		$I_O = 40 \text{ mA}$		
Output On-Current Rating	$ I_{O(\text{ON})} $			40	mA	$V_O \leq 8 \text{ V}$, $T_A \leq 40^{\circ}\text{C}$		1
Output Off-Resistance	$R_{(\text{OFF})}$	50	10,000		G Ω	$V_O = 200 \text{ V}$	6	6
Output Off-Leakage Current	$I_{O(\text{OFF})}$		0.02	4.0	nA	$V_O = 200 \text{ V}$	6	
Output Off-Capacitance	$C_{(\text{OFF})}$			4.5	pF	$V_O = 0 \text{ V}$, $f = 1 \text{ MHz}$	7	
Output Offset Voltage	$V_{O(\text{OS})}$	Note 3	-0.2	Note 3	μV	$I_O = 0 \text{ A}$; $I_F = 1 \text{ mA}$	8, 17, 18	3
			-1.3			$I_O = 0 \text{ A}$; $I_F = 5 \text{ mA}$		
Input Reverse Breakdown Voltage	V_R	3	10		V	$I_R = 10 \mu\text{A}$		
Input Diode Temperature Coefficient	dV_F/dT		-1.75		mV/ $^{\circ}\text{C}$	$I_F = 1 \text{ mA}$		
Input Forward Voltage	V_F		1.5	2.0	V	$I_F = 5 \text{ mA}$	9	
Input Capacitance	C_{IN}		21		pF	$V_F = 0 \text{ V}$; $f = 1 \text{ MHz}$		

Switching Specifications

$-40^{\circ}\text{C} \leq T_A \leq +85^{\circ}\text{C}$, $1 \text{ mA} \leq I_{F(\text{ON})} \leq 5 \text{ mA}$, $0 \text{ V} \leq V_{F(\text{OFF})} \leq 0.6 \text{ V}$, and all Typicals at $T_A = 25^{\circ}\text{C}$ unless otherwise specified.

Parameter	Symbol	Min.	Typ.	Max.	Units	Test Conditions	Fig.	Notes
Turn On Time	t_{ON}		50	200	μs	$I_F = 5 \text{ mA}$	$V_O = 50 \text{ V}$	10, 11, 12, 13
			300	1500		$I_F = 1 \text{ mA}$		
Turn Off Time	t_{OFF}		45	250	μs	$I_F = 5 \text{ mA}$	$V_O = 50 \text{ V}$	10, 11, 12, 13
			75	350		$I_F = 1 \text{ mA}$		
Output Transient Rejection	dV_O/dt	2000	≥ 7000		V/ μs	$\Delta V_O = 200 \text{ V}$	$T_A = 25^{\circ}\text{C}$	14
						$\Delta V_O = 50 \text{ V}$		
Input-Output Transient Rejection	dV_{I-O}/dt	2000	≥ 7000		V/ μs	$\Delta V_{I-O} = 300 \text{ V}$	$T_A = 25^{\circ}\text{C}$	15
						$\Delta V_{I-O} = 50 \text{ V}$		

Package Characteristics

For $-40^{\circ}\text{C} \leq T_A \leq +85^{\circ}\text{C}$, unless otherwise specified. All Typicals at $T_A = 25^{\circ}\text{C}$.

Parameter	Symbol	Min.	Typ.	Max.	Units	Test Conditions	Fig.	Notes
Input-Output Momentary Withstand Voltage*	V_{ISO}	2500			V rms	RH = 45%, t = 1 min, $T_A = 25^{\circ}\text{C}$		4, 5
Resistance Input-Output	$R_{\text{I-O}}$	100	100,000		G Ω	$V_{\text{I-O}} = 500 \text{ VDC}$, t = 1 min, RH = 45%		4
Capacitance Input-Output	$C_{\text{I-O}}$		0.6	1.0	pF	$V_{\text{I-O}} = 0 \text{ V}$, f = 1 MHz, $T_A = 25^{\circ}\text{C}$		4

*The Input-Output Momentary Withstand Voltage is a dielectric voltage rating that should not be interpreted as an input-output continuous voltage rating. For the continuous voltage rating refer to the VDE 0884 Insulation Characteristics Table (if applicable), your equipment level safety specification, or HP Application Note 1074, "Optocoupler Input-Output Endurance Voltage."

Notes:

- Derate linearly above 40°C at a rate of $0.3 \text{ mA}/^{\circ}\text{C}$.
- Derate linearly above 60°C at a rate of $5 \text{ mW}/^{\circ}\text{C}$.
- $V_{\text{O(ON)}}$ is a function of $I_{\text{F(ON)}}$, and is defined between pins 8 and 5 with pin 5

as reference. $V_{\text{O(ON)}}$ must be measured in a stable ambient. See Figure 8 for variation of $V_{\text{O(ON)}}$ around the typical value.

- Device considered a two terminal device: pins 1 and 4 shorted together, and pins 5 and 8 shorted together.

- This is a momentary withstand proof test. These parts are 100% tested in production at 3000 Vrms, one second.
- $R_{\text{(OFF)}}$ is defined as $V_{\text{O(OFF)}}/I_{\text{O(OFF)}}$.

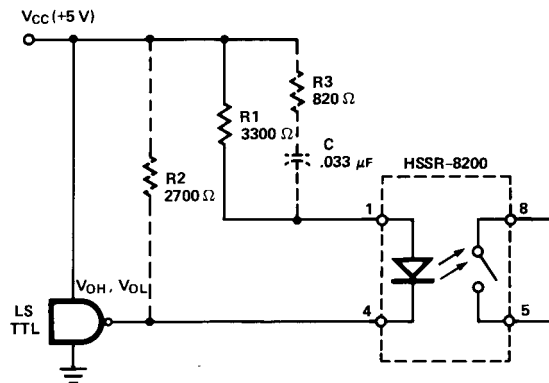

- R1 - REQUIRED CURRENT-LIMITING RESISTOR FOR $I_{\text{F(ON)}} = 1 \text{ mA}$
R2 - PULL-UP RESISTOR FOR $V_{\text{F(OFF)}} < 600 \text{ mV}$; IF $(V_{\text{CC}} - V_{\text{OH}}) < 600 \text{ mV}$, OMIT R2
R3, C - OPTIONAL PEAKING CIRCUIT FOR $I_{\text{F(PK)}} = 5 \text{ mA}$, $t_{\text{ON}} < 200 \mu\text{s}$

Figure 2. Recommended Input Circuit.

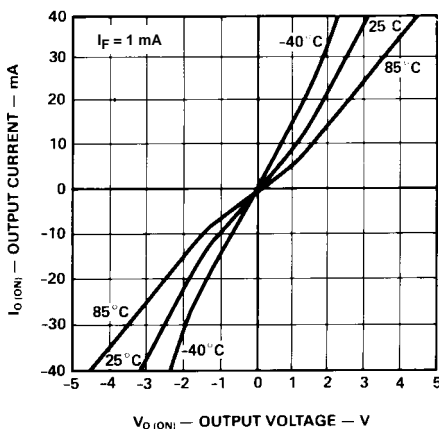

Figure 3. Typical On State I-V Characteristics.

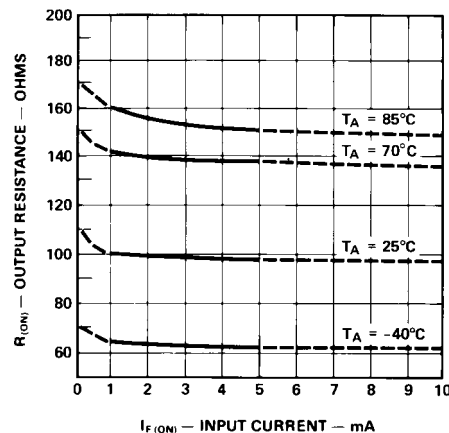

Figure 4. Typical Output Resistance vs. Input Current.

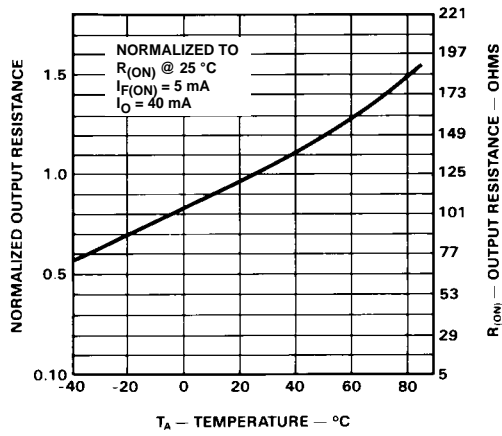

Figure 5. Typical Output Resistance vs. Temperature.

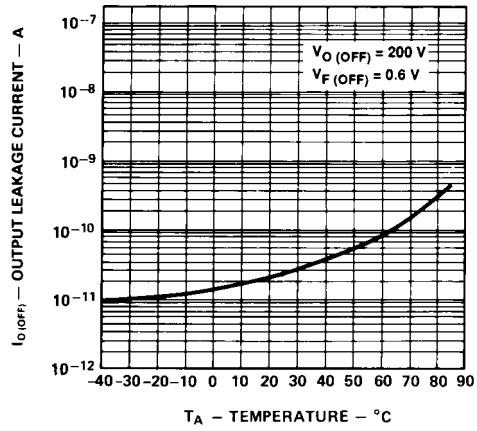

Figure 6. Typical Output Leakage vs. Temperature.

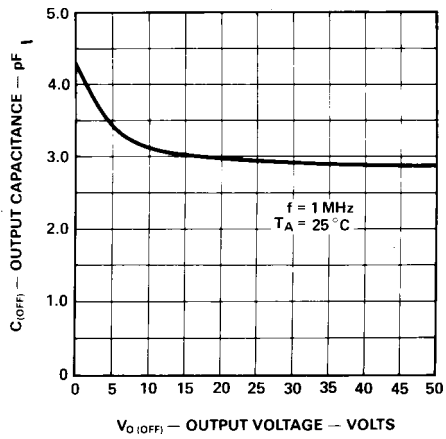

Figure 7. Typical Output Capacitance vs. Output Voltage.

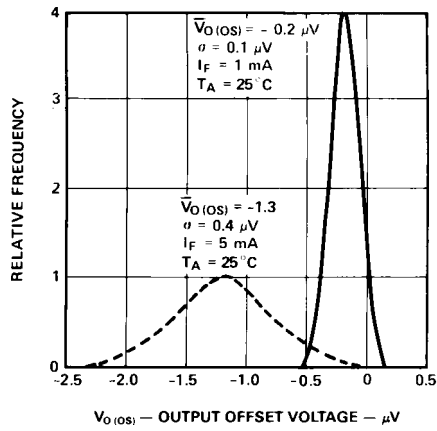

Figure 8. Output Offset Voltage Distribution.

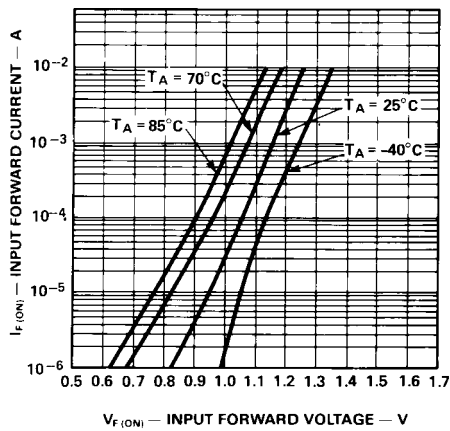

Figure 9. Typical Input Forward Current vs. Forward Voltage.

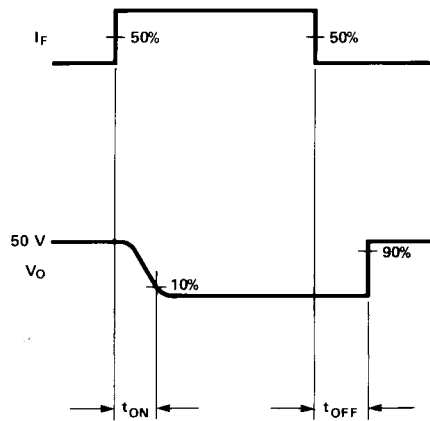

Figure 10. Switching Test Circuit for t_{ON} , t_{OFF} .

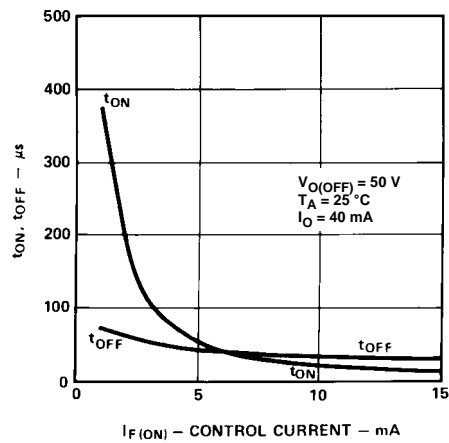
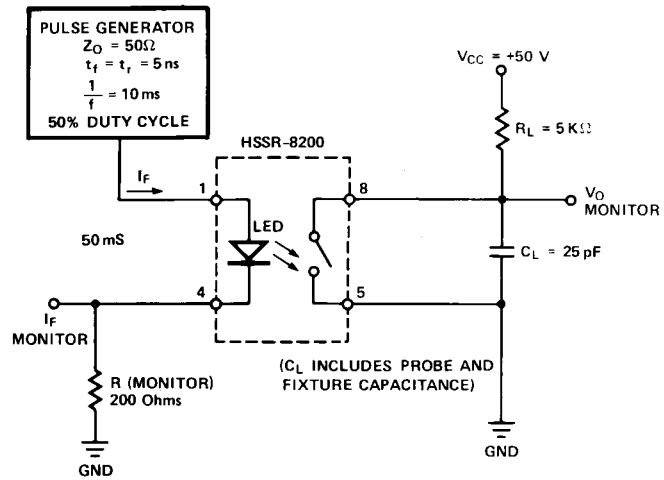

Figure 11. Typical t_{ON} and t_{OFF} vs. Input Current.

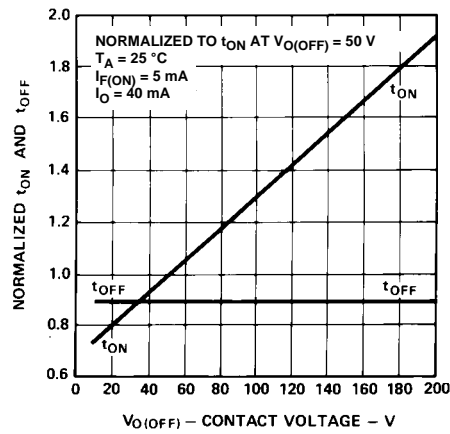

Figure 12. t_{ON} and t_{OFF} vs. Output Voltage.

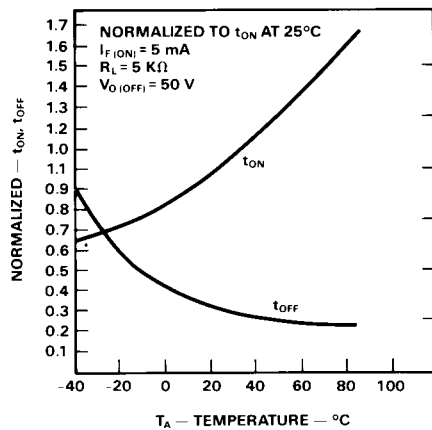

Figure 13. Normalized t_{ON} and t_{OFF} vs. Temperature.

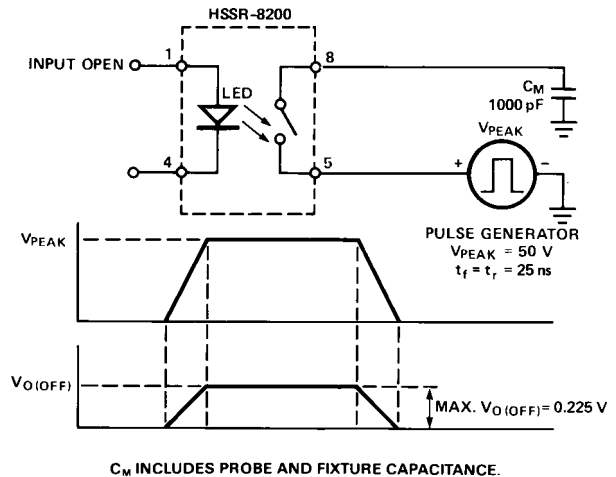

Figure 14. Output Transient Rejection Test Circuit.

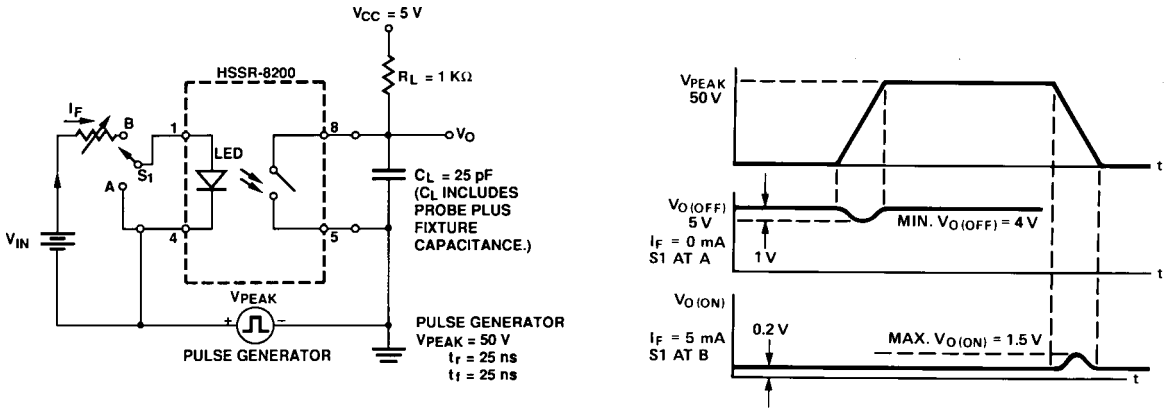

Figure 15. Input-Output Transient Rejection.

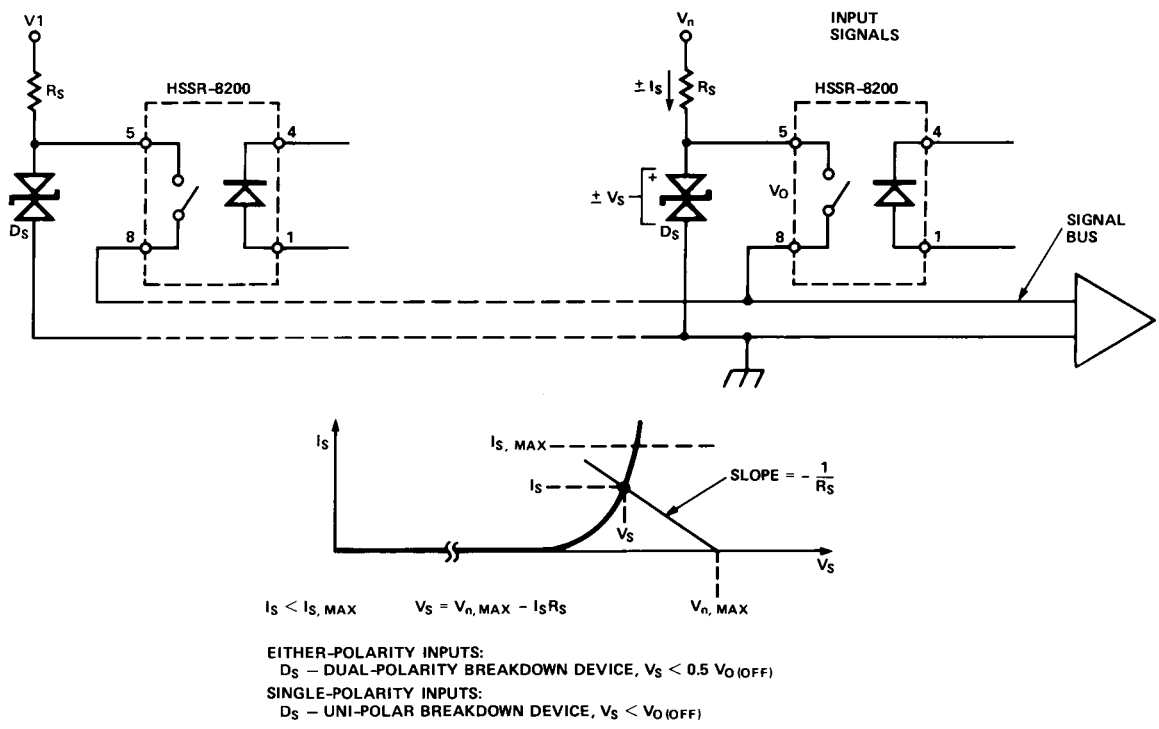

Figure 16. Over-Voltage Protection in Multiplexer Applications.

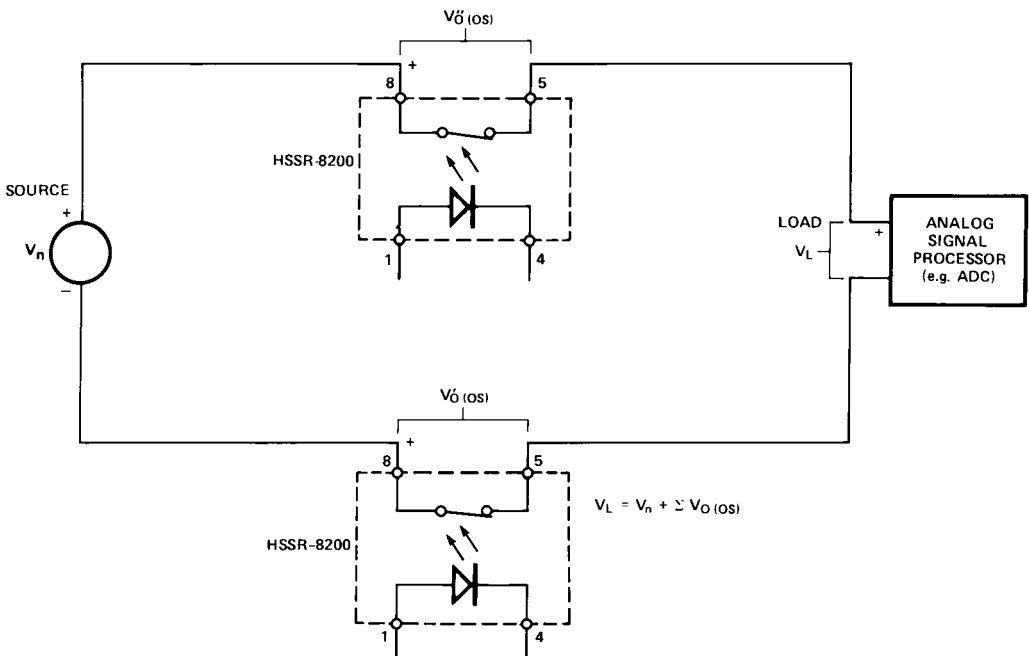

Figure 17. Differential Output Connections to Minimize Offset Voltage Effects.

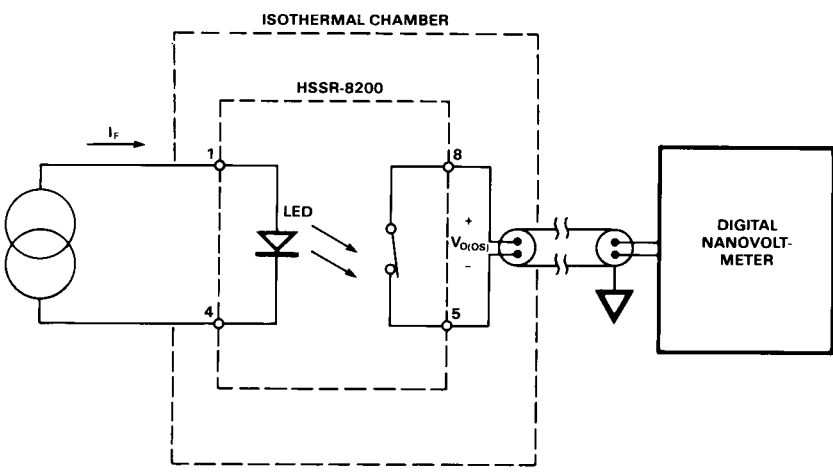

Figure 18. Voltage Offset Test Setup.